

PowerCharge™



INSTALLATION MANUAL

**POWERCHARGE™
EZ-PULL PEDESTAL SYSTEM**

PowerChargeEV.com

INDEX

Introduction - For use with PowerCharge™ Energy 4

Safety Instructions 4

Single and Dual Post and Cable Management System for PowerCharge™ Energy 5

Concrete Pad, Power Feed, and Anchor Requirements for PowerCharge™ Energy 6

Single/Dual Post and Cable System Installation 7

Single PowerCharge™ Energy Mounting 9

Dual PowerCharge™ Energy Mounting 10

Single/Dual Post and Cable System Base Plate Dimensions 11

FIGURES

Figure 1.1	Cable Unwound	8
Figure 1.2	Charging Cable Midway Point	8
Figure 1.3	Cable Hovers Above Ground	8
Figure 2.	72"/95" Single Post - Front View	9
Figure 3.	72"/95" Single Post - Side View	9
Figure 4.	72"/95" Single Post - Back View	9
Figure 5.	72"/95" Dual Post - Front View	10
Figure 6.	72"/95" Dual Post - Side View	10
Figure 7.	72"/95" Dual Post - Back View	10
Figure 8.	Base Plate Diagram	11

INTRODUCTION - FOR USE WITH ALL POWERCHARGE™ ENERGY SERIES MODELS

Applications include any residential or commercial, public, or private, where Electric Vehicle (EV) charging is required. Indoors or outdoors is acceptable.

These instructions do not imply to cover all details or variations in equipment, or to provide for every possible contingency to be met in connection with installation, operation, or maintenance. Should further information be desired, or should problems arise which are not covered sufficiently for the purchaser's purposes, the matter should be referred to Customer Service available at **(585) 533-4085**.

The warranty contained in the contract between the parties is the sole warranty of PowerCharge™. Any statements contained herein do not create new warranties or modify the existing warranty.

NOTE: Due to the weight of the post and assembly, more than one person is required to safely install both the single and dual posts.

NOTE: This instruction outlines the recommended general procedure for installation by a qualified person, as defined by all local electrical codes and/or the NEC®.

PERMITS: Be aware that many areas require special permits and/or utility approvals to install EV charging equipment. Contact your local electrical inspector's office and your local utility prior to beginning work to understand local requirements.

WARRANTY: See PowerCharge™ standard terms and conditions below with regards to warranty of purchase.

TOUCH UP PAINT: See link below for replacement paint, if needed for aesthetic restoration throughout the post's life: <https://www.lvppaints.com/RAL7035-Color-Plate.html>

Safety Instructions:



DANGER Hazardous voltage. Will cause death or serious injury. Disconnect before working on this equipment. This indicates a situation where the present voltage could cause injury or death. Extreme caution is required when servicing or installing the equipment referenced.



DANGER Explosion hazard. This equipment has arcing or sparking parts that should not be exposed to flammable vapors. Use extreme caution and follow instructions carefully.



WARNING! This indicates a situation where failure to follow instructions may be a safety hazard or cause equipment malfunction. Use extreme caution and follow instructions carefully.

© The National Electrical Code is a registered trademark of the National Fire Protection Association

SINGLE AND DUAL POST AND CABLE MANAGEMENT SYSTEM FOR POWERCHARGE™

PowerCharge™ units sold separately

Features:

- Single or dual mount pedestal
- PowerCharge™ standard bolt pattern
- Aluminum pedestal post with retractor
- Aluminum pedestal base with 3" x 6" raceway
- Powder coated for environmental durability
- Pedestal base doubles as an electrical raceway

Supplied Parts:

- One (1) Pedestal Base Assembly (11.5" x 11.5" x 32.25")
- One (1) Retractor Assembly (10.25" x 2.56" x 72"/95")
- One (1) PowerCharge™ mounting bracket (for single or dual)
- One (1) 3" x 6" Plastic Top Cap
- Four (4) ¼-20 x ½" Machine Button Head Screws with two (2) nuts
- Two (2) ¾" NM Flex Right-Angle Connector
- Three (3) ¾" NM Flex Straight Thru Connector
- Fourteen (14) 10 - 32 x ½" Machine Button Head Screws with nuts
- Four (4) Drop-In Anchors
- Four (4) Stainless Anchor Bolts with Washers
- Four (4) 1" Conduit Hole Plugs
- Four (4) Conduit Reducing Washers, 1" NPT to ¾" NPT
- Two (2) Liquid-tight flex conduit, ¾" X 12"
- One (1) Liquid-tight flex conduit, ¾" X 6"
- One (1) Tube of Silicone with applicator tip
- Two (2) Rubber Spacer for Cable Clamps
- Two (2) Rubber thread caps, ¼"

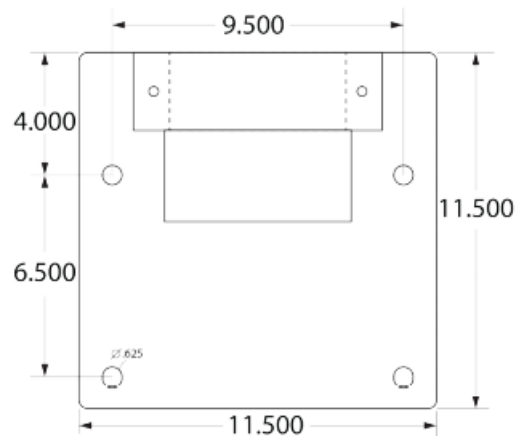

Viewed from Underneath Pedestal Base

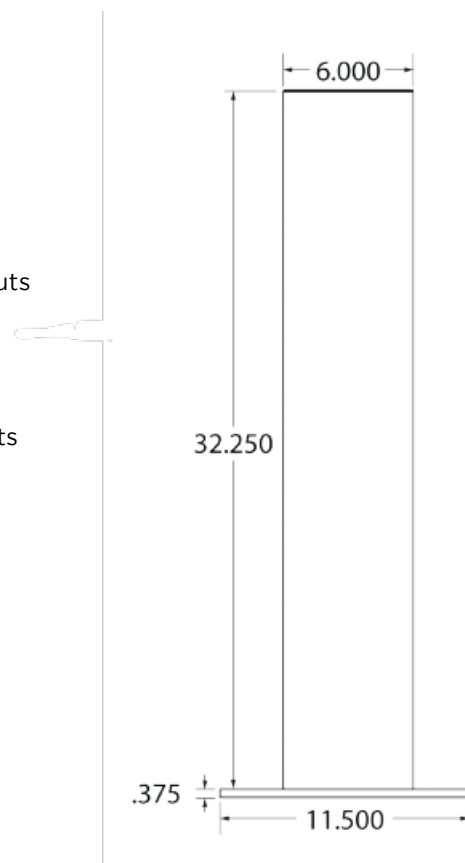

All pedestals are factory pre-drilled for installing one (1) or two (2) PowerCharge™ EVSE units (specify when ordering). The product is compatible with all PowerCharge™ Energy Series models.

Installation height is regulated by NEC®, however, this can vary based on local jurisdiction. NEC® 2011 specifies: Outdoor (NEC® Article 625.30B) defines installation of an EV Charging Station as 24-48 inches above the grade (to any reach point). Use appropriate tools and hardware to fasten equipment, see details.

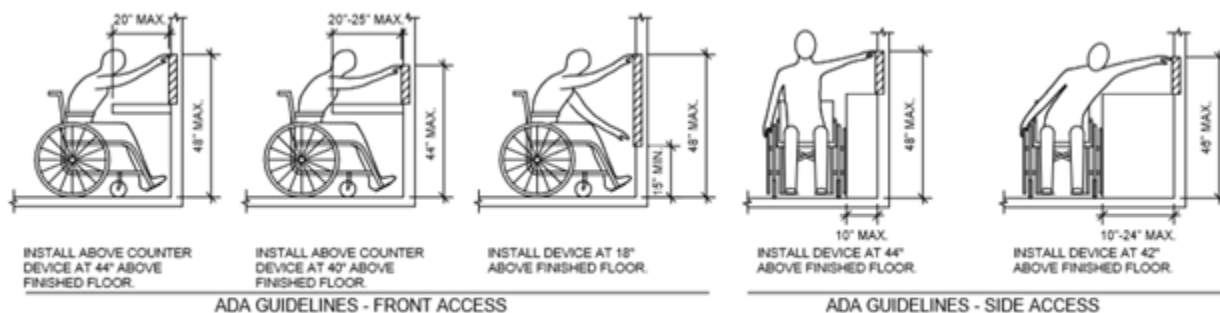

ADA STANDARDS FOR ACCESSIBLE DESIGN

CONCRETE PAD, POWER FEED, AND ANCHOR REQUIREMENTS FOR POWERCHARGE™

Provide an approved concrete or composite base with the top flush at ground level with 36" conduit stub-up centered. The base size should be a minimum of 18" x 18" x 18" and can be poured or pre-cast / pre-made. Installation of protective steel bollard post(s) and/ or curb stops to protect the charger from an automobile strike is recommended. Using the provided drop-in anchors (with a concrete base), secure the pedestal to the base. If using a composite base, such as the EV Charge Solutions® 'No-Pour Base', secure per manufacturer's instructions. <https://www.evchargesolutions.com/EV-Charge-Solutions-No-Pour-Base-p/evcs-base-a-01.htm>

There is an option to run the power supply wires underground, feeding through the bottom opening in the pedestal or, if the conduits are run above ground, the wires may be brought in through the sides of the post using the lower 1" holes on each side of the pedestal base. When using above ground conduits, use 3/4" NPT liquid-tight fittings to enter through 1" holes in lower section of the pedestal.

Feed-wire size shall be determined by a qualified electrician using industry standard calculations.

NOTE: The power feed conduit shall be sized to provide three wires (L1, L2, GND) for each charger being mounted. Install the wires so they extend sufficiently above the ground for direct attachment to the EVSE (the charger). The raceway is NOT rated to be water-tight, so use of Liquid-tight conduits and fittings is required.

SINGLE/DUAL POST AND CABLE SYSTEM INSTALLATION

1. Remove assembly from the two (2) packages. Remove the metal mounting bracket and hardware from its box and set aside.
2. Place the pedestal-base assembly onto the concrete (or composite) mounting base. A minimum base size of 18" x 18" x 18" of reinforced concrete is recommended. Composite bases designed for EVSE installation are also an option, such as the EV Charge Solutions® 'No-Pour Base'.

<https://www.evchargesolutions.com/EV-Charge-Solutions-No-Pour-Base-p/evcs-base-a-01.htm>

3. Center the base plate over the conduit if underground conduit is used and mark the four mounting hole locations onto the base. Remove the pedestal assembly.
4. Drill mounting holes in the base. **NOTE:** The included drop-in anchors require a 5/8" hole.
5. Clean debris from the holes and install drop-in anchors using the proper setting tool (not included).
6. Place the pedestal-base assembly onto the concrete base while completing (a) or (b) below. Bolt-down the pedestal base using the included drop-in anchors making sure the base is level. Shim base plate if necessary (shims not included).
 - a) If conduit is stubbed up through base from underground routing, feed the power and communication wires through the opening in the base of the 3" x 6" raceway.
 - b) If conduit is above ground, remove hole plug(s) and connect conduits to the lower 1" holes in the sides of the 3" x 6" raceway using 3/4" NPT connectors.

Attach the retractor assembly to the pedestal base lower plate by inserting 1/4-20 machine button head screws into the threaded base plate. Attach the upper portion using the upper holes to the 3x6" raceway using 1/4-20 machine button head screws and nuts. (Do not over-tighten.). Place (2) 1/4" rubber caps over the exposed threads inside the raceway.

7. Install the 90-degree conduit NM connectors on the raceway (one for single EVSE post and two for dual EVSE post). Feed the power wires (L1, L2, and GND) through the NM connectors.
8. Install the top cap onto the raceway and secure it using a thin bead of silicone adhesive (included). If using communication wires, feed through the hole in the 3x6" cap. If not installing communication wires, plug the hole with the included plug.
9. Mount the aluminum (single or dual) PowerCharge™ mounting bracket onto the retractor post using four (4) 10 - 32 x 1/2" screws. Install (one or two) Energy Series EV chargers onto the bracket using the bracket supplied with the Energy Series charger and the included 10 - 32 x 1/2" screws.
10. Place PowerCharge™ charger(s) onto the bracket(s).
11. **Verify Power is NOT Present at the feed wires!** Remove the front cover of the charger(s). Attach the power wires (L1, L2, and GND) as per the PowerCharge™ Installation and Operations Manual. Use the included Liquid-Tight conduit and fittings between the conduit stub-up and charger(s).

Once the wires are connected, reattach the charger cover(s). Be sure to use a proper wire length to allow the charger cover to reattach without pinching or obstructing.

12. Install the security-torx bolt to secure the charger to bracket.

13. Attaching cable clamp to charging cable:

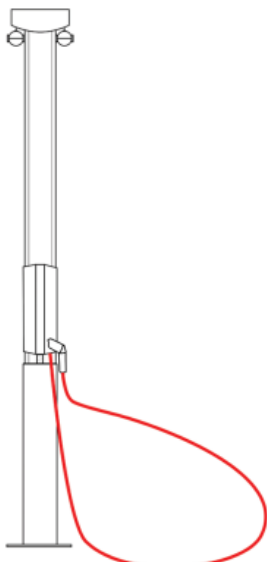

Figure 1.1 Cable Unwound

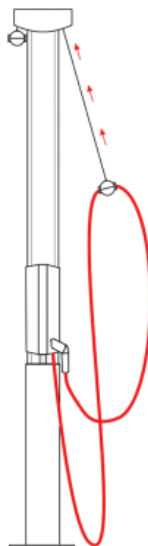

Figure 1.2 Charging Cable Midway Point



Figure 1.3 Cable Hovers Above Ground

13-A. Ensure the charging station is properly installed to the pedestal/retractor system.

13-B. Remove the bottom half of the cable clamp by removing the two screws and set aside.

13-C. Unravel the charging cable by removing any twists and holster the charging station connector to the connector dock. See Figure 1.1 Cable Unwound.

13-D. Find the approximate mid-way point of the charging cable. Without tightening the screws all the way, loosely attach the cable clamp to the charging cable and retract to starting point. The cable should freely slide/move within the clamp. See Figure 1.2 Charging Cable Midway Point.

13-E. Slide the cable positioning until you've achieved a loop from charging station to clamp:

- Both loops should hover above the ground. See Figure 1.3 Cable Hovers Above Ground.

13-F. If necessary, insert the included rubber spacers between the cable clamps and cables, creating a tight grip on the cable as you tighten the screws (electrical tape can also be used). The cable should not move within the clamp.

13-G. For Dual Cable Retractor Systems, repeat steps 1-13F on opposite side of the post.

15. Turn on the power feed to the charging station(s) and test, as per the PowerCharge™ installation manual.

SINGLE POWERCHARGE™ MOUNTING

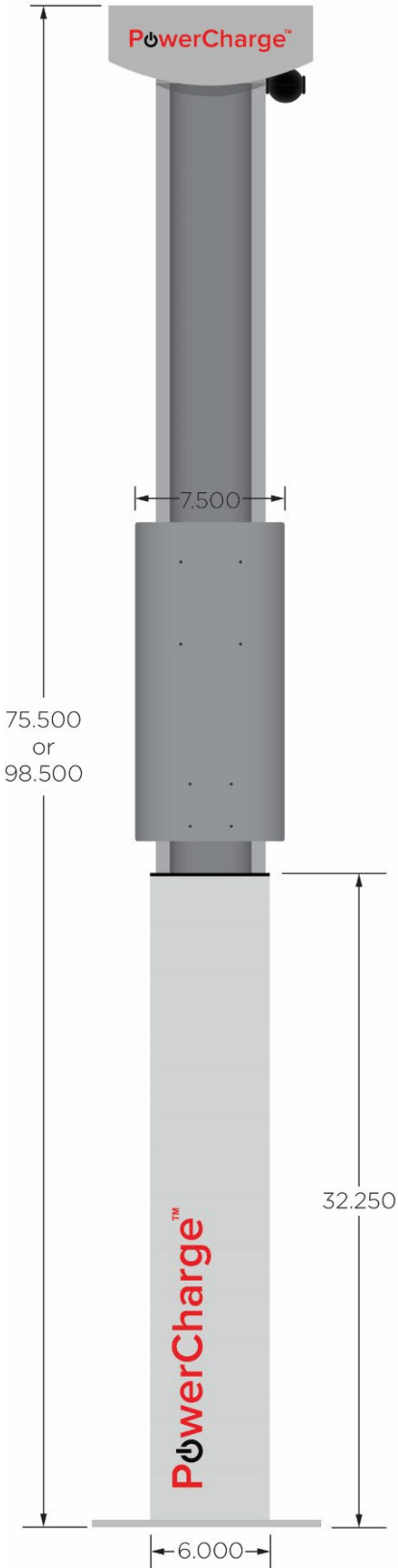

Figure 2.

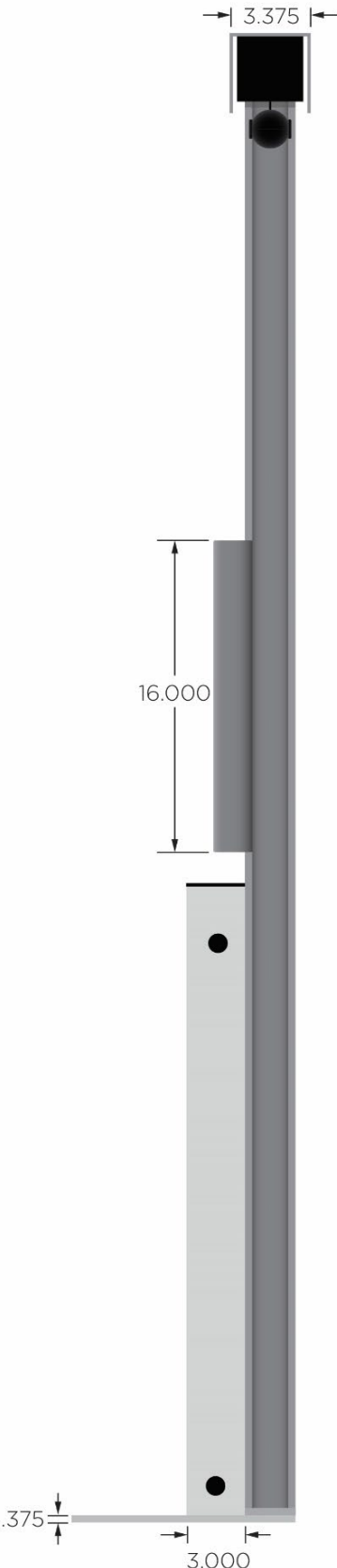

Figure 3.

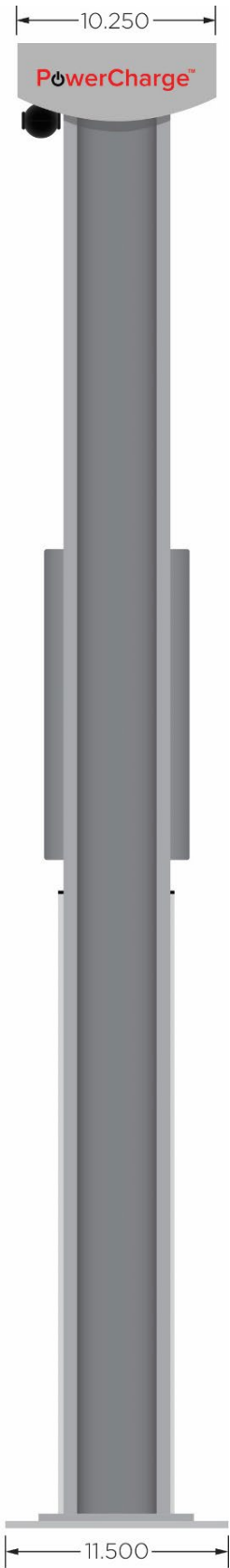

Figure 4.

DUAL POWERCHARGE™ MOUNTING

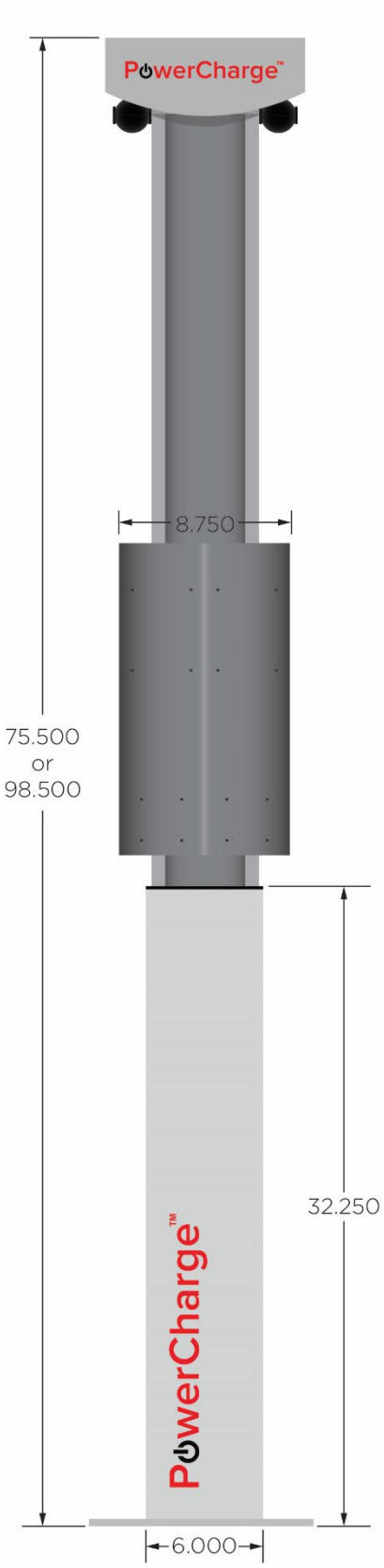

Figure 5.

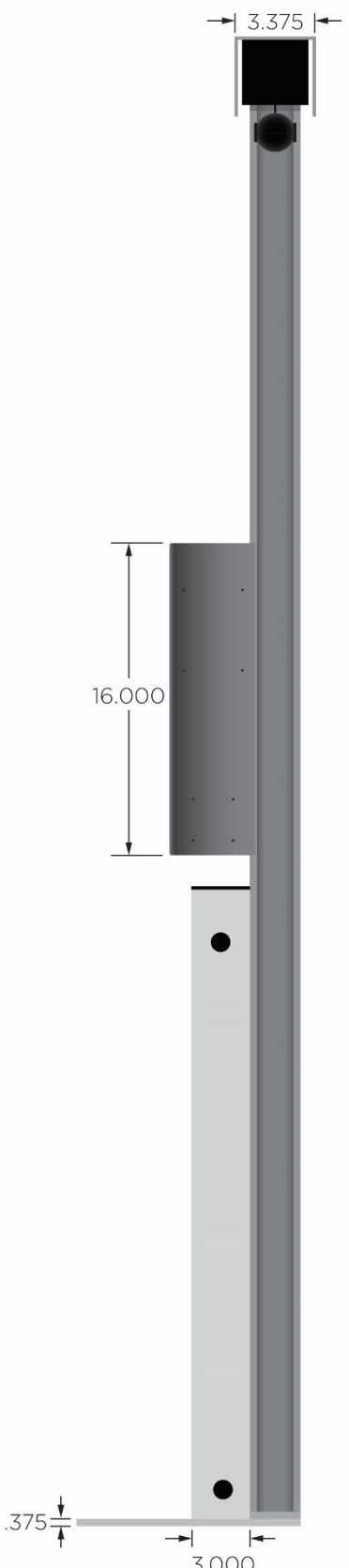

Figure 6.

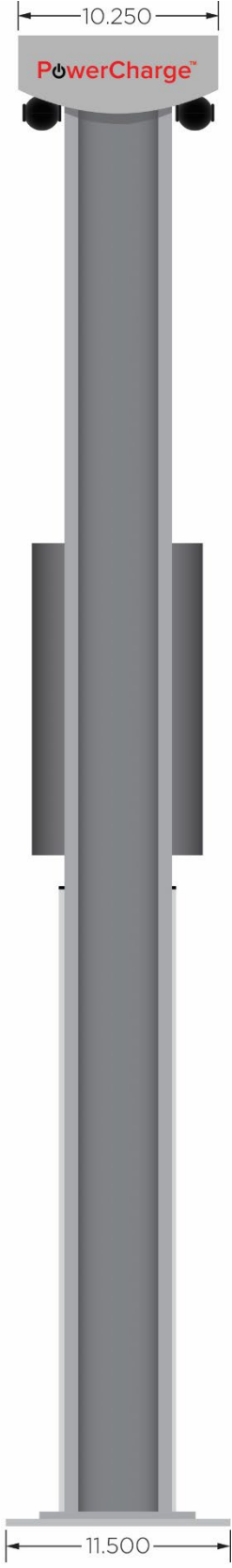

Figure 7.

SINGLE/DUAL POST AND CABLE SYSTEM BASE PLATE DIMENSIONS

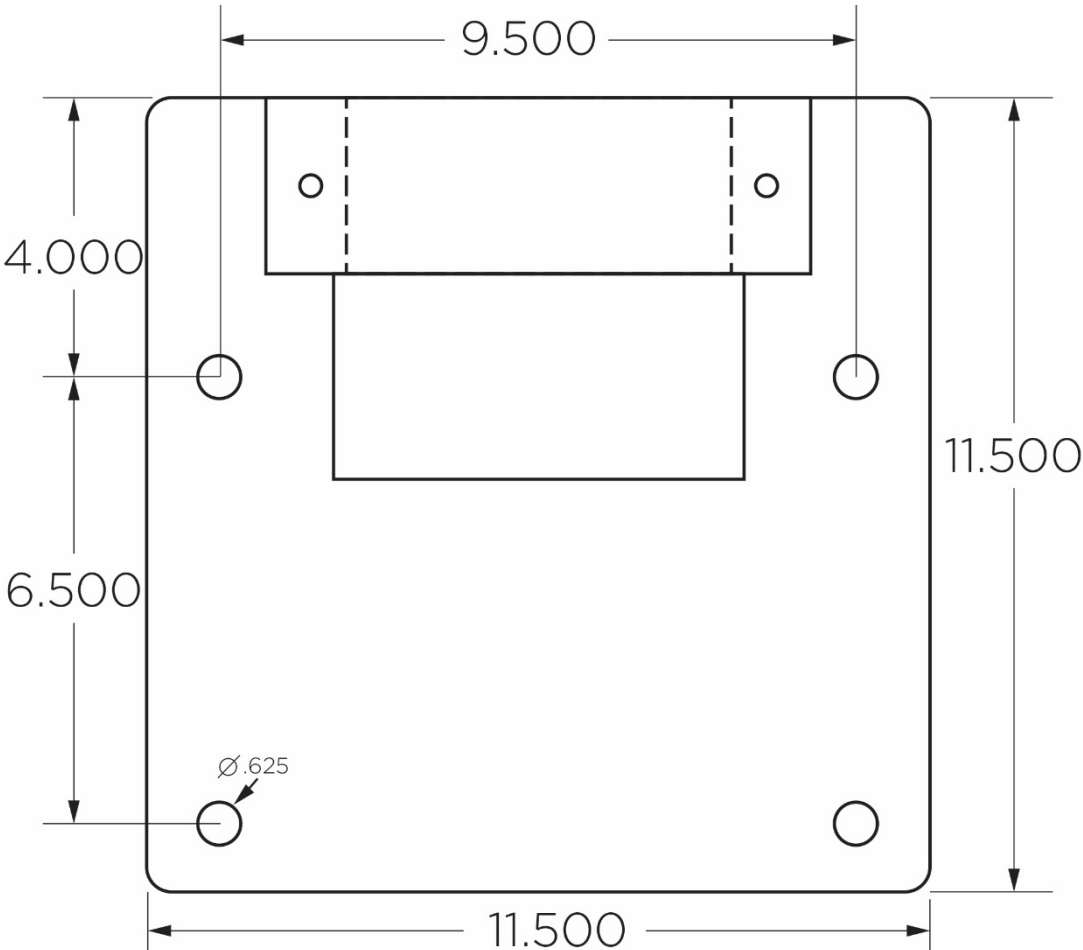

Figure 8.

POWERCHARGE™

500 CANAL VIEW BLVD, SUITE 100

ROCHESTER, NY 14623

PowerChargeEV.com | info@PowerChargeEV.com | 585-533-4085